

Normas de Referência

Construção

ASME B 16.34

Testes

API 598

Conexões

ROSCA BSP - ISO 228

ROSCA NPT - ANSI/ASME B 1.20.1

SOLDA SW - ASME B 16.11

SOLDA BW - ASME B 16.25

Materiais

Corpo e Tampas

ASTM A216 - WCB

ASTM A351 - CF8

ASTM A351 - CF8M

Esfera

ASTM A351 - CF8M

Vedações

PTFE | COMP L

Haste

AISI - 304

AISI - 304L

AISI - 316

AISI - 316L

AISI - 1020

AISI - 410

AISI - 416

Outros materiais sob consulta



IMAGEM MERAMENTE ILUSTRATIVA

Especificações Técnicas

Válvula Direcional de fluxo Classe 300, disposta de uma entrada inferior e duas saídas utilizadas para desviar alternadamente o fluxo.

Construção tripartida (um corpo e duas tampas), facilitando a manutenção sem a necessidade de desconectar as extremidades da linha.

Haste à prova de expulsão.

Disponível na construção com dupla vedação, o que proporciona maior segurança quando utilizadas em linha de vapor.

Não indicada como válvula para bloqueio de fluxo.

De fácil aplicação para trava de cadeado.

Dados Técnicos

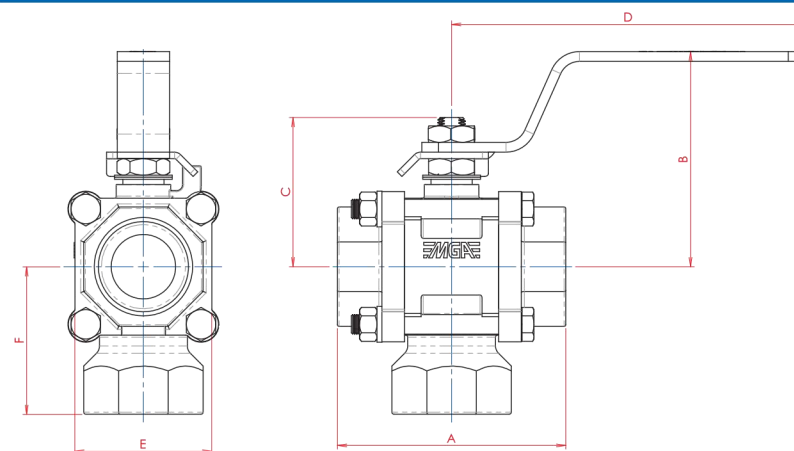

TIPOS DE CONEXÕES

ENCAIXE DE SOLDA SW

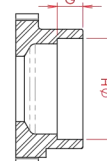

ROSCA BSP OU NPT

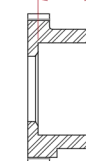

ENCAIXE DE SOLDA BW

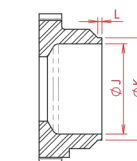

POSIÇÃO 0°

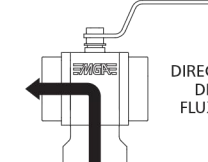

POSIÇÃO 90°

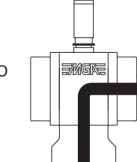

DIREÇÃO DE FLUXO

VÁLVULA DE ESFERA DIRECIONAL PASSAGEM REDUZIDA (PR)

BITOLA		PASS.	A	B	C	D	E	F	G	H	I	J	K	L	PESO kg
POL.	DN														
1/2"	15	11,1	62,0	46,0	39,0	125,0	43,5	47,0	9,5	21,8	17,0	15,8	21,8	2,0	0,562
3/4"	20	14,0	71,6	48,0	41,0	125,0	48,0	51,8	12,5	27,1	17,0	20,9	27,1	2,0	0,699
1"	25	20,4	88,6	82,0	51,0	165,0	57,0	56,4	12,5	33,8	23,0	26,4	33,8	2,0	1,200
1.1/4"	32	25,4	101,0	86,0	60,0	165,0	64,0	67,0	12,5	42,6	23,0	35,0	42,6	2,0	1,552
1.1/2"	40	31,7	111,7	110,0	73,0	170,0	73,0	71,7	12,5	48,7	28,0	41,0	48,7	3,0	2,468
2"	50	38,0	121,5	113,0	77,0	170,0	81,5	82,8	16,0	61,0	28,0	52,5	61,0	3,0	3,204
2.1/2"	65	50,8	138,8	125,0	86,0	256,0	94,0	101,0	16,0	73,8	28,0	62,7	73,8	3,0	5,030
3"	80	63,0	176,5	145,0	116,0	267,0	116,0	121,8	16,0	90,1	37,0	78,0	90,1	3,0	8,870

VÁLVULA DE ESFERA DIRECIONAL PASSAGEM PLENA (PP)

BITOLA		PASS.	A	B	C	D	E	F	G	H	I	J	K	L	PESO kg
POL.	DN														
1/4"	8	11,1	62,0	46,0	39,0	125,0	43,5	47,0	9,5	14,0	11,0	9,3	14,0	2,0	0,584
3/8"	10	11,1	62,0	46,0	39,0	125,0	43,5	47,0	9,5	17,6	11,0	12,3	17,6	2,0	0,575
1/2"	15	14,0	71,5	48,0	41,0	125,0	48,0	51,8	9,5	21,8	17,0	15,8	21,8	2,0	0,731
3/4"	20	20,4	88,6	82,0	51,0	165,0	57,0	56,4	12,5	27,1	17,0	20,9	27,1	2,0	1,248
1"	25	25,4	101,0	86,0	60,0	165,0	64,0	67,0	12,5	33,8	23,0	26,4	33,8	2,0	1,557
1.1/4"	32	31,7	111,7	110,0	73,0	170,0	73,0	71,7	12,5	42,6	23,0	35,0	42,6	2,0	2,540
1.1/2"	40	38,0	121,5	113,0	77,0	170,0	81,5	82,8	12,5	48,7	28,0	41,0	48,7	3,0	3,431
2"	50	50,8	138,8	125,0	86,0	256,0	94,0	101,0	16,0	61,0	28,0	52,5	61,0	3,0	5,390
2.1/2"	65	63,0	176,5	145,0	116,0	267,0	116,0	121,8	16,0	73,8	28,0	62,7	73,8	3,0	9,320

